

STORING YOUR SHOTGUN IN A CARRYING CASE IS NOT ADVISABLE. RUST MAY OCCUR DUE TO TRAPPED MOISTURE IN THE CASE.

## 1-SAFETY RULES

**WARNING: THE FAILURE TO FOLLOW THESE SHOTGUN SAFETY REQUIREMENTS WILL CAUSE SERIOUS PERSONAL INJURY OR DEATH TO YOU OR OTHERS.**

- ALWAYS TREAT A FIREARM AS IF IT WERE LOADED. NEVER ASSUME THAT IT IS UNLOADED.
- NEVER POINT THE FIREARMS AT SOMETHING THAT IS NOT SAFE TO SHOOT.
- ALWAYS STORE FIREARMS TO PREVENT CHILDREN FROM HAVING ACCESS TO THEM. IT IS YOUR RESPONSIBILITY TO INSURE THAT UNAUTHORIZED PERSONS DO NOT GAIN ACCESS TO YOUR FIREARM. TO REDUCE THE RISK OF ACCIDENTS INVOLVING CHILDREN, UNLOAD YOUR FIREARM, LOCK IT AND STORE THE AMMUNITION IN A SEPARATE LOCKED LOCATION.
- ALWAYS WEAR ADEQUATE AND PROPER EAR PROTECTORS.
- ALWAYS WEAR SAFETY PROTECTIVE GLASSES SPECIFIED FOR FIREARM USE.
- ALWAYS BE ALERT AND ALWAYS FOLLOW THE SAFETY INSTRUCTIONS OF THE RANGE OFFICER. NEVER SHOOT IF YOU ARE TIRED, COLD OR IMPAIRED IN ANY WAY.
- ALWAYS BE AWARE OF YOUR SURROUNDINGS, AND BE ALERT THAT PEOPLE CAN WALK INTO YOUR LINE OF FIRE.
- THE SHOOTER (AND ALL OTHERS IN THE SHOOTING AREA) MUST ALWAYS BE IN A POSITION THAT IS OUT OF THE LINE OF FIRE.
- NEVER SHOOT AT HARD SURFACES, WATER OR RANDOMLY INTO THE SKY. ALWAYS SELECT A PLACE TO SHOOT THAT HAS A SAFE BACKSTOP AND IS FREE FROM OBSTRUCTIONS AND WATER SURFACES WHICH CAUSE RICOCHETS.
- NEVER CLIMB A TREE, FENCE OR OBSTRUCTION WITH A LOADED FIREARM. OPEN AND EMPTY THE CHAMBER OF YOUR FIREARM AND ENGAGE THE MANUAL SAFETY BEFORE CLIMBING OR DESCENDING A TREE OR BEFORE CLIMBING A FENCE OR JUMPING OVER A DITCH OR OBSTRUCTION.
- NEVER TRANSPORT A LOADED FIREARM.
- NEVER USE ALCOHOL OR DRUGS BEFORE OR WHILE SHOOTING OR HANDLING ANY FIREARM.

## 2-NOMENCLATURE

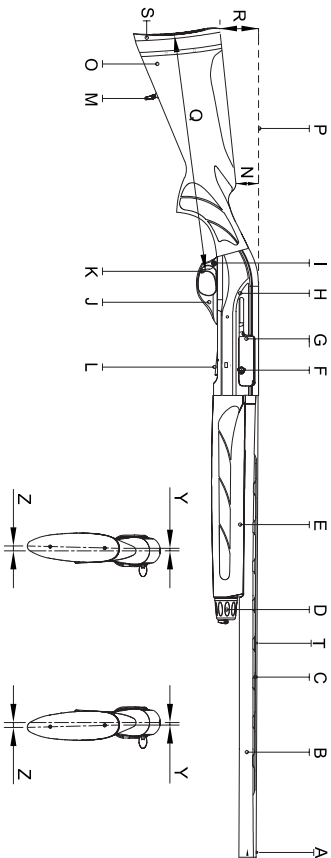

- |                                 |                                  |                                  |
|---------------------------------|----------------------------------|----------------------------------|
| <b>A</b> Bead Front Sight       | <b>H</b> Receiver                | <b>O</b> Stock                   |
| <b>B</b> Barrel                 | <b>I</b> Safety                  | <b>P</b> Line of Sight           |
| <b>C</b> Top Rib                | <b>J</b> Trigger Group Housing   | <b>Q</b> Length of Pull          |
| <b>D</b> Fore-End Retaining Nut | <b>K</b> Trigger                 | <b>R</b> Drop at Heel            |
| <b>E</b> Fore-End               | <b>L</b> Carrier                 | <b>S</b> Butt Plate / Recoil Pad |
| <b>F</b> Cocking Handle         | <b>M</b> Stock Swivel (Complete) | <b>T</b> Mid Sight               |
| <b>G</b> Bolt (Complete)        | <b>N</b> Drop at Comb            | <b>Y</b> Top Advance Angle       |
|                                 |                                  | <b>Z</b> Bottom Advance Angle    |

### 3-INITIAL ASSEMBLY AND INSPECTING

- Your shotgun is shipped from the factory with the barrel not assembled to the receiver (Figure 1).



- Unscrew the fore-end retaining nut (Figure 2) and remove the fore-end by pulling it forward (Figure 3).



- Next, assemble the barrel to the receiver (Figure 4). When doing this you might need to pull/release the cocking handle for easier fitting. Assemble the fore-end (Figure 5) and then screw on the fore-end retaining nut (Figure 6).



## 4-SAFETY BUTTON

The safety is designed to stop the trigger mechanism.

The safety on any gun is a mechanical device, and it is not intended as a substitute for common sense or safe gun handling. Always keep the muzzle pointed in a safe direction.

- The safety is located behind the trigger, and provides protection against accidental or unintentional discharge under normal usage when properly engaged.
- To engage the safety, push the button from the left side so that it protrudes from the right side of the gun and the RED RING CAN NOT BE SEEN (Figure 7). The safety should always be in the “on” or “safe” position until you intend to fire the gun.
- When you are ready to fire the gun, press the safety button to the “off” or “fire” position, so that the safety protrudes from the left side of the shotgun and the RED RING APPEARS (Figure 8).

**WARNING: The gun will fire when the trigger is pulled intentionally or accidentally when the RED RING APPEARS.**



## 5-LOADING AND USAGE

**WARNING: WHILE LOADING, KEEP THE SAFETY "ON" AT ALL TIMES AND KEEP THE MUZZLE POINTED IN A SAFE DIRECTION.**

To load your semi-automatic shotgun, pull the cocking handle backward until it is locked (Figure 9) and press the bolt release button (Figure 10). Looking at the bottom of the gun, you will see that it is possible to move the carrier upward into the receiver. You can now insert shells in the magazine tube using your thumb (Figure 11). Note that your gun is factory limited to 3 shells - 2 in the magazine and 1 in the chamber - using a magazine plug. To chamber a shell when you are done with loading, push the shell drop lever located at the back of the carrier (Figure 12), and pull the cocking handle backward and a shell will come out of the magazine tube moving into the chamber with the support of the carrier (Figure 13). When you pull and release the cocking handle, the first round will get chambered and you are ready to fire. As the first shell is chambered, you can add one more shell into the magazine tube.

**WARNING: To prevent unexpected ignition and potential injuries, be certain that each round you use is in the proper gauge!**

**Always keep your fingers away from the trigger while loading and unloading your gun!**



Figure 9



Figure 10



Figure 11



Figure 12



Figure 13

## 6-UNLOADING THE SHOTGUN

**WARNING: WHILE UNLOADING, KEEP THE SAFETY “ON” AT ALL TIMES AND KEEP THE MUZZLE POINTED IN A SAFE DIRECTION.**

Push the bolt release button and the carrier upward simultaneously. You will see that the shells will be ejected from the magazine tube (Figure 14). When all the shells are ejected, check the chamber by pulling the cocking handle backwards so that any shell in the chamber will be ejected (Figure 15).

**Always keep your fingers away from the trigger while loading and unloading your gun.**



## 7-DISASSEMBLY

- Unscrew the fore-end retaining nut (Figure 16), and remove the fore-end (Figure 17). Take the barrel off by pulling it forward (Figure 18).



- While holding the action bar with one hand, pull the cocking handle out of the bolt (Figure 19&20) and take the bolt assembly, action bar and recoil spring out of the receiver assembly (Figure 21&22). Take the gas piston located in the gas chamber out that is under the barrel by pulling it with your fingernails (Figure 23)

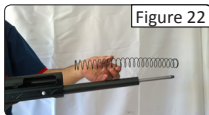

- Using a tool (if necessary, a soft head hammer) remove the pin (Figure 24) and take the trigger group housing out (Figure 25).



## 8-REASSEMBLY

- Insert the trigger group housing into the receiver (Figure 26) and secure it with its pin gently (Figure 27). Before putting the trigger group housing into its place, make sure that the hammer is cocked. Figure 28 shows the cocked state, and Figure 29 shows the decocked state of the hammer.



Figure 26



Figure 27



Figure 28



Figure 29

- Afterwards, mount the recoil spring and insert the action bar and bolt group to the receiver (Figure 30), and insert the cocking handle into its slot (Figure 31).



Figure 30



Figure 31

- Now, insert the gas piston into the gas chamber located under the barrel (Figure 32), and attach the barrel to the receiver (Figure 33), assemble the forend (Figure 34), and finally screw on the forend retaining nut (Figure 35).



Figure 32



Figure 33



Figure 34



Figure 35



## 9. ADJUSTABLE STOCK

- Each shotgun is provided with a set of stock shims to assist the shooter in obtaining a personalized fit to the sighting plane. The stock is user adjustable for either cast or stock drop. This adjustment is made by replacing the plastic shim located between the receiver and the stock (Figure 36). Note that only one shim can be inserted between stock & receiver.



The factory installed shim is marked CIP which provides a neutral cast and standard drop dimensions of the comb. The shim kit includes two replacement shims that change the cast of the stock, either Left 5 or Right 5. These spacers do not affect the stock drop.

The kit includes three replacement shims that change the drop of the stock. The slope of the drop in the stock can be changed from standard to -10, or -5 or a positive 5 direction.

Replacing the stock shim requires the removal of the adjustable butt pad. The adjustable butt plate pad is attached by two Philips head screws. To detach the pad;

- Loosen the butt plate locking screws located at the lateral surface of the heel with the Allen wrench provided in the packaging (Figure 37).
- By rotating the recoil pad, locate the screws on the pad (Figure 38).
- Remove the two screws located on the aluminum pad (Figure 39).

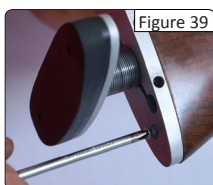
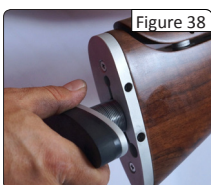
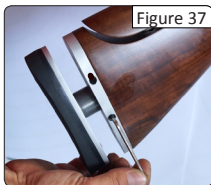

## 9. ADJUSTABLE STOCK

- Once the adjustable butt plate is removed, loosen and remove the stock bolt and its washer using a 10mm wrench (Figure 40), and pull the stock free from the receiver (Figure 41).



- Remove and replace the shim for a personalized stock fit (Figure 42), and re-attach the stock and tighten the stock bolt (Figure 43).
- Re-attach the adjustable butt plate pad by attaching the screws (Figure 44)
- Retighten the butt plate locking screws (Figure 45).

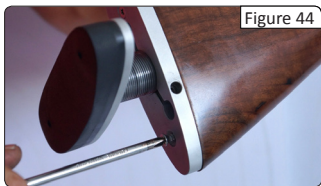
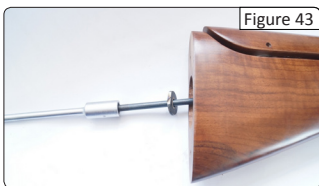

## 10. ADJUSTABLE COMB STOCK

- The point of impact of the shotgun can be adjusted by moving the comb of the stock. The comb hardware can be adjusted both horizontally and vertically, allowing the shooter to personalize the fit of the shotgun stock.
- To adjust the comb, loosen the two set screws on the side of the comb with the allen wrench (Figure 46).



- Lift the comb upward off the support posts (figure 47), and remove the washers from the posts.
- To adjust the horizontal alignment of the comb, loosen the screw in the top of the post with the allen wrench (Figure 48).



- Slide the post in the desired direction, and re-tighten post at desired location.
- Moving the post to the left will cause the shotgun to shoot to the left. A change of  $1/16''$  in the comb position will cause a change in the point of impact of approximately 2" at 30 yards. The base plates are etched with  $1/16''$  reference lines to aid the shooter in determining the amount of pattern movement when re-positioning the comb (Figure 49).



## 10. ADJUSTABLE COMB STOCK

- Slide the washers over the posts to adjust the height of the comb.
- By raising the comb height with the washers, the shotgun will shoot a higher point of impact. The washer thickness is approximately 1/16" and each washer will move the impact point upward approximately 1 ½ inches at 30 yards (Figure 50).
- After you have made your desired adjustment, place comb over the posts and tighten the two set screws in the side of the comb with the allen wrench (Figure 51).



## 11. ADJUSTABLE BUTT PLATE

The length of pull (LOP) is the distance measured from the center of the trigger shoe to the center of the butt pad. This dimension is adjustable and the selected distance relates generally to the shooter's physique and the preferred placement of their cheek on the comb of the stock.

- To adjust the length of pull (LOP) of your shotgun, first loosen the butt plate locking screws located at the lateral surface of the heel with the Allen wrench provided in the packaging (Figure 52), then rotate the butt plate either in or out of the base plate. To increase the LOP rotate counterclockwise; to decrease the LOP rotate clockwise (Figure 53).

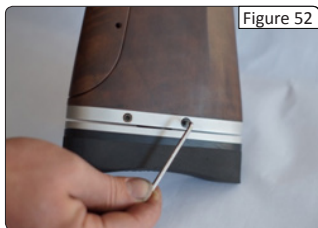

Figure 52

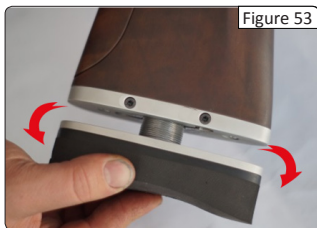

Figure 53

The cast of the pad can be adjusted to reduce the canting effect of the barrels due to the stocks fit to a person's shoulder pocket. A proper cast at toe, adjustment will reduce felt recoil and improve the consistency in the point of impact of the shot pattern.

- To adjust the cast of the pad; loosen the butt plate locking screws, then pivot the butt plate to the desired location (Figure 54). Once you have completed the adjustment to meet your satisfaction, tighten the butt plate locking screws located on the lateral side of the heel (Figure 55).



Figure 54

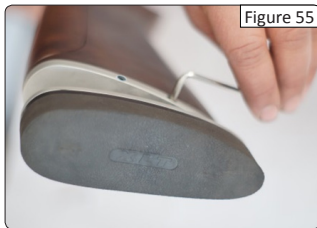
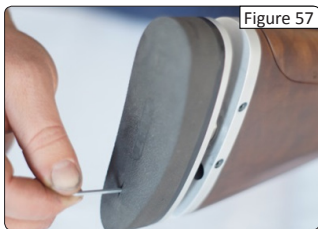
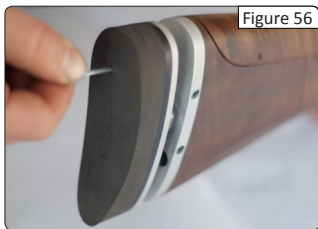

Figure 55

## 11. ADJUSTABLE BUTT PLATE

Adjustments to the height of the comb and the location of the butt pad allow each shooter to individualize the fit of the stock to their own physique. Adjusting the drop at the heel (DAH) of the stock insures that the face of the pad fits correctly into the shoulder pocket and reduces felt recoil.

- To adjust the height of the butt plate, use the Allen wrench provided to unscrew the butt pad from the plate (Figure 56&57).





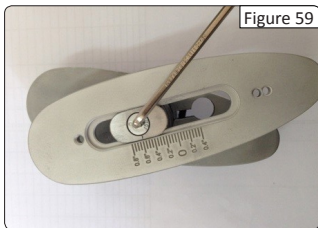

- Now loosen the lock screw located in the center of the butt plate using the Allen wrench provided (Figure 58).
- The inscribed reference lines on the butt plate allow for precise adjustment of the plate (Figure 59). Once you have completed the adjustment to meet your satisfaction, tighten the butt plate lock screw (Figure 51), and re-install the butt pad (Figure 58& 59).



## 12. INSTALLATION OF CHOKE TUBES

With the choke tubes you can control the openness or tightness of the pattern of your shotgun. The chart below lists the chokes available (from open to tight), and the corresponding marks that indicate the choke of your shotgun.

AMERICAN DESIGNATION	CL (Cylinder)	IC (Improved Cylinder)	M (Modified)	IM (Improved Modified)	F (Full)
CHOKE TUBE					
NOTCHES	★★★★★	★★★★	★★★	★★	★
COMPATIBILITY WITH STEEL SHOT	Recommended	Recommended	Recommended	Not Recommended	Not Recommended
BEST IN THE AREA OF	Sporting, clay and skeet shooting. Short distance, more open shooting.	Quail, dove and target shooting. For shorter distance more open shooting.	Hunting woodcock, pheasant & quail with 30-35 yard shots. Long range hunting with steel shot and tight groups.	For hunting pheasant, ducks with 30-40 yard shots.	For duck and goose hunting with 40-45 yard shots. For long range hunting with lead shot and tight groups.

All the five choke tubes are included in the package in a specially designed box (Figure 60). Note that "M (Modified)" choke tube is factory mounted.



**WARNING:** When installing a choke tube in your barrel, make sure that the tube is completely screwed down tight in the barrel, never shot your shotgun without the choke tubes installed as this may damage the barrel and injure the shooter. Choke tubes may become loose after extended firing and should be checked frequently of tightness.

## 13. USE OF CHOKE TUBES

### INSTALLATION OF CHOKE TUBES

**WARNING:** Check that the firearm is unloaded. If not, unload the firearm by operating as described in the chapter “Unloading the shotgun”. Never look into the muzzle or change tube on a loaded gun; even with safety is set “on”.

- Apply a thin coat of gun oil to the threads of the barrel and of the choke tube.
- Insert the desired choke into the choke housing. Take care the notched end will be upside.
- Carefully hand screw the choke into the barrel clockwise (Figure 61).
- Using the choke tube Wrench; tighten the choke until it is fully bottomed into its recess in the barrel.
- Remove the choke tube wrench after tightening.

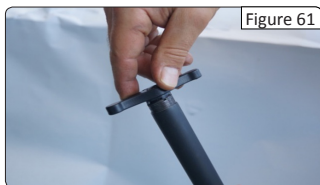



## 13. USE OF CHOKE TUBES

### REMOVAL OF CHOKE TUBES

**WARNING:** Check that the firearm is unloaded. If not, unload the firearm by operating as described in the chapter “Unloading the shotgun”. Never look into the muzzle or change tube on a loaded gun, even with safety engaged.

- Unscrew (counterclockwise) the choke tube using the choke tube wrench supplied (Figure 62). Remove the choke tube from the muzzle (Figure 63).

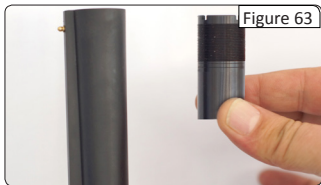

### CLEANING OF CHOKE TUBES

**WARNING:** Check that the firearm is unloaded. If not, unload the firearm by operating as described in the chapter “Unloading the shotgun”. Never look into the muzzle or change tube on a loaded gun, even with safety is set “on”.

- Carefully clean the choke housing. If necessary, use a cotton patch coated with gun oil.
- Check the choke to make sure it is perfectly clean inside and outside.
- Apply a thin coat of gun oil to the threads of the barrel and of the choke tube.

## 14. PARTS LIST

1	Receiver	41	Ejector Rivet (Short)
3	Magazine Tube	41-A	Shell Ejector Retaining Pin
4	Rear Magazine Plug	42-A	Piston
5	Magazine Spring	42-B	Gas Discharge Washer
6	Front Magazine Plug	42-C	Gas Discharge Spring
7	Recoil Spring	42-D	Gas Discharge Retaining Screw
8	Stock Retaining Nut	43	Forend
9	Stock	44	Barrel
9-A	Shim	45	Sling Swivel Support
9-B	Adjustable Stock	46	Magazine Plug
10	Stock Washer	47	Forend Retaining Nut Spring
12	Through Bolt	48	Forend Retaining Nut
13	Recoil Pad	49	Safety Button
14	Butt Screws (2 Pieces)	50	Safety Spring Guide
15	Sling Swivels (2 Pieces)	51	Safety Spring
16	Sling Swivel Screws (2 Pieces)	52	Safety Spring Pin
17	Sling Swivel Capscrew (Stock)	53	Trigger
18	Bolt Release Button Spring	54	Disconnecter Spring
19	Bolt Release Button	55	Disconnecter Spring Pin
20	Bolt Release Button Pin	56	Disconnecter
21	Carrier Lock Spring	57	Disconnecter Pin
22	Carrier Lock	58	Trigger Spring
23	Carrier Lock Pin	59	Trigger Stop Pin
24	Cocking Handle Bearing Pin	60	Trigger Pin
25	Cocking Handle Bearing Spring Barrel Ring Ratchet Spring	61	Carrier Lever
26	Cocking Handle Bearing Screw Barrel Ring Ratchet Screw	62	Carrier
27	Extractor Spring	63	Carrier Lever Rivet
28	Extractor	64	Hammer Spring
29	Extractor Retaining Pin	65	Hammer Spring Guide
30	Locking Block	66	Hammer
31	Locking Block Spring	67	Hammer Retaining Pin
32	Fring Pin Spring	68	Retaining Circlip
33	Firing Pin	69	Shell Drop Lever Spring
34	Firing Pin Screw	70	Shell Drop Lever
35	Follower Pin	71	Shell Drop Lever Pin
36	Bolt	72	Carrier Lever Spring
37	Action Bar	73	Carrier Lever Spring Pin
38	Cocking Handle	74	Trigger Group Housing
39	Ejector	75	Trigger Group Retaining Pin
40	Ejector Rivet (Long)	76	Sight Bead
40-A	Shell Ejector Spring	76-A	Middle Bead Sight
		77	Choke Tube
		78	Adjustable Butt Plate

## NOTES

## NOTES

## 16-CLEANING AND MAINTENANCE

**WARNING: ENSURE THAT YOUR FIREARM IS UNLOADED BEFORE BEGINNING TO CLEAN IT.**

At the end of the day of shooting/hunting, clean and lubricate the shotgun.

**Cleaning procedure:**

- Disassemble the shotgun (see paragraph "Disassembly").
- Clean the bores with care by passing a cleaning rod with a cotton patch coated with a high-quality gun oil to remove combustion residues. Also include the chambers in your cleaning operation.
- Do not forget to clean choke tubes and choke threads in the muzzle. Failure to clean these areas will result in the inability to remove the choke from the barrel and severe damage to the muzzle. If a choke tube becomes tight in the muzzle, this is an indication that the thread requires cleaning.
- Run a clean dry patch through the bores to remove oil residues.
- Lightly oil the inside of the barrels with a clean cotton patch coated in high-quality gun oil.
- Clean with care the external surfaces of the shotgun to remove any trace of dirt, sweat and fingerprints.
- Make sure you do not touch the metal parts while you are putting your shotgun back into its place of storage.
- Regularly clean the gas chamber and piston for proper cycling of your gun.

Always follow the instructions provided with your gun cleaner and gun lubricant. Whenever your firearm has been exposed to sand, dust, extreme humidity water or other adverse conditions, it must be cleaned and lubricated.

After an intensive period of use, check the operation of the bolt assembly and if necessary, clean and lubricate it using suitable gun oil.

If your firearm will be used in a cold climate, be sure to use an oil of an appropriate weight so that it will not congeal in cold temperatures.

NEVER MANIPULATE, ADJUST OR CHANGE ANY OF THE INTERNAL COMPONENTS OF YOUR FIREARM.

ANY MAINTENANCE, ADJUSTMENT OR SERVICE NOT SPECIFIED IN THIS MANUAL MAY AFFECT THE SAFETY AND RELIABILITY OF YOUR FIREARM AND MUST BE PERFORMED BY AN AUTHORIZED GUN-SMITH USING GENUINE FACTORY PARTS. IF YOU DO OTHERWISE, IMPROPER FUNCTIONING OF YOUR FIREARM MAY OCCUR AND SERIOUS INJURY OR DEATH MAY RESULT.

When storing, do not encase the shotgun in anything that will attract or hold moisture, for example; leather or heavy cloth. Also, do not store shotguns with a plug inserted in the barrel for this can be a contributing factor to moisture accumulation. If the shotgun is to be stored for an extended period, the bore, chamber and internal surfaces should be oiled with a high-quality lubricating oil preservative intended for firearms.

The external parts; receiver, bolt and barrel should be coated with an anti-rust oil.



## USER'S MANUAL HYBRID SYSTEM SEMI-AUTOMATIC MODELS



**READ THE INSTRUCTIONS AND WARNINGS IN THIS MANUAL BEFORE USING THIS SHOTGUN!**

## INDEX

1. SAFETY RULES.....	3
2. NOMENCLATURE.....	4
3. INITIAL ASSEMBLY AND INSPECTING.....	5
4. SAFETY BUTTON.....	6
5. LOADING AND USAGE.....	7
6. UNLOADING THE SHOTGUN.....	8
7. DISASSEMBLY.....	9
8. REASSEMBLY.....	10
9. ADJUSTABLE STOCK.....	11-12
10 ADJUSTABLE COMB STOCK.....	13-14
11 ADJUSTABLE BUTT PLATE.....	15-16
12. INSTALLATION OF CHOKE TUBES.....	17
13. USE OF CHOKE TUBES.....	18-19
14. PARTS LIST.....	20
15. EXPLODED VIEW.....	21-22
16. CLEANING AND MAINTENANCE.....	23

## 15-EXPLODED VIEW

